



Planetary mixers

10/20 liters

Impastatrici planetarie
10/20 litri



Standard 220V - 1Ph - 50/60Hz

mac.pan

STANDARD EQUIPMENT

SAFETY AND HYGIENE

- According to European Law EN 453
- Detachable product conveyor on the rear protection
- Food-grade aluminium cam to avoid that paint or eventual rust comes in contact with the product
- Utensil shaft in stainless steel
- 24 volt control panel

EQUIPMENT

- 1 bowl
- 1 whisk
- 1 spatula
- 1 spiral

EQUIPAGGIAMENTO DI SERIE

SICUREZZA E IGIENE

- Protezione anteriore a norma legge europea EN 453
- Convogliatore prodotto amovibile sulla protezione anteriore
- Eccentrico in alluminio alimentare per evitare che vernice o eventuale ruggine possa entrare a contatto con il prodotto
- Albero porta utensile in acciaio inox
- Pannello di comando 24 volt

EQUIPAGGIAMENTO

- 1 vasca
- 1 frusta
- 1 spatola
- 1 spirale

Our machines are designed, manufactured and assembled in ITALY. - Le nostre macchine sono progettate, costruite e assemblate in ITALIA.



MODEL	Components	PL 10 min/max	PL 20 min/max	RPM min/max
BREAD	Kg flour + 50% water	0,4/2	1/4,5	35/50
PIZZA DOUGH		0,4/2	1/4,5	35/50
CROISSANT		0,4/2	1/4,5	35/70
BRIOCHE		0,4/2	1/5	35/80
EGG WHITE	Number of eggs	0,4/14	10/30	110/150
MERINGUE	Kg of sugar	0,4/1	0,5/1,5	110/150
BISCUITS	Number of eggs	5/15	10/30	120/150
SPONGE CAKE	Number of eggs	5/15	10/30	120/150
FRESH PASTA	Kg flour	0,1/8	0,2/1,6	40/60

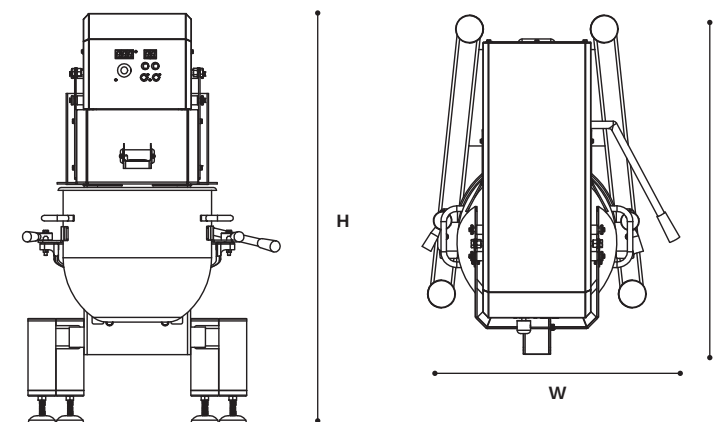

MODEL	bowl capacity lt	speeds n°	variable speeds tool rpm	power kW	dimensions (WxDxH) mm	weight Kg
PL10/VAR	10	variable	40 → 200	0,37	410X490X570	34
PL20/VAR	20	variable	45 → 180	0,75	580X700X870	74

As continued product improvement is a policy of MAC.PAN Srl, specifications are subject to change without notice.

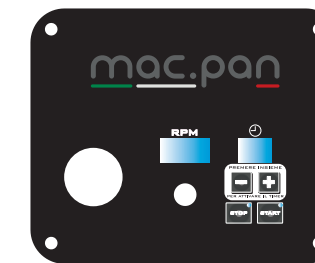

Variation of bowl revolutions from 40 to 150 rpm
1 digital timer 0.99 minutes, with memory.
variazione dei giri vasca da 40 a 150 giri/min
1 timer digitale 0,99 minuti, con memoria

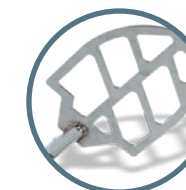

MIXING - MESCOLAZIONE

The mixing must be performed in 2 speed. Mayonaise, waffle, cookies, pie, icing, fondant.

La mescolazione va eseguita in 2 velocità. Maionese, pasta brisée, glass, cialde.



EMULSION/BEATEN - EMULSIONE/MONTATURA

Must be performed in 3 speed. Meringue, whipped cream, cake.

Va eseguita in 3 velocità. Biscotti, creme, meringhe, bianco d'uovo, puree, torte.



KNEADING - IMPASTO

The kneading must sometimes be performed in 1 speed, in 2 speed for some types of mix hard.

Bread, pizza, croissant, brioches.

L'impasto va eseguito in 1 velocità talvolta in 2 velocità per certi tipi di impasti consistenti.

Pane, pizza, croissant, brioches in genere.



Pedestal
Piedistallo