

SPECIFICATIONS

Dimensions

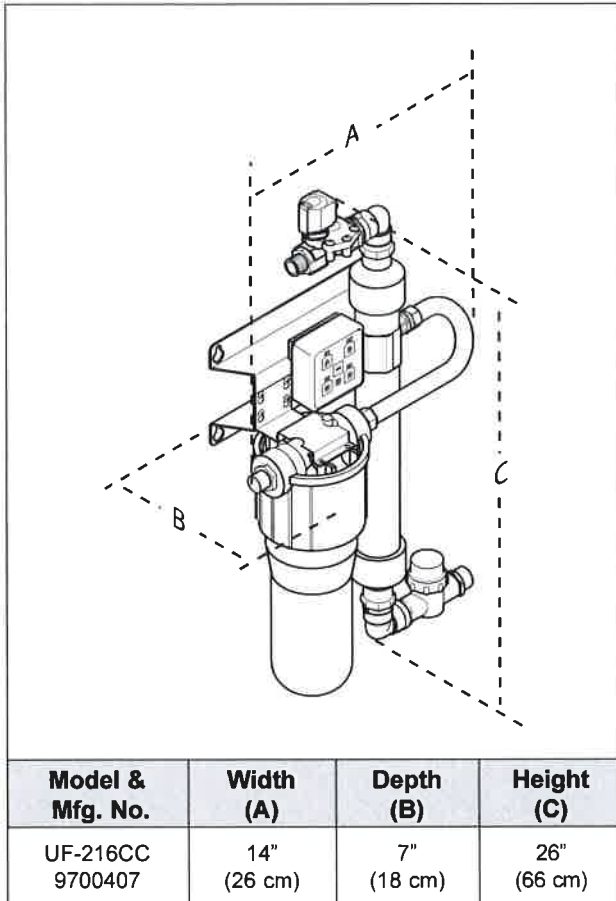

Electrical Ratings

Model & Mfg. No.	Voltage	Watts	Amps	Hertz
UF-216CC 9700407	100-240	10	0.8	50/60

Electrical Cord & Plug Configurations

Kit Model Number	Description	Configuration
0012146	DC Power Supply 100 - 240 VAC Includes the 4 plug adaptors below	
	US NEMA 1-15 (2 pin) or NEMA 5-15 (3 Pin)	
	Euro CEE 7/16	
	AS/NZS 3112 AUS (2 Pin)	
	UK BS 1363	

Replacement Cartridges

Replacement Cartridge		Part No.
UF-216CC	Ultra Filter Cartridge	2090162

Ultra Filter Cartridge Capacities

Max. Operating Pressure	100 psig (690 kPa)
Max. Operating Temp.	104°F (40°C)
Min. Operating Temp.	40°F (4°C)
Max. Trans Membrane Pressure	45 psi (3.1 bar)
pH Range	3-10
MWCO	100 kD

⚠ CAUTION ⚠

All electrical connections must be in accordance with local electrical codes and any other applicable codes.

A ground fault circuit interrupter (GFCI) must be installed on the circuit to this system.

When installed on metallic plumbing, a properly sized electrical bonding jumper must be installed across the inlet and outlet pipes serving this device