

Muffin Toaster | MT



MT-12
includes spatula

Create an irresistible breakfast sandwich by serving it on a perfectly toasted English muffin. With the MT-12 Muffin Toaster, operations can toast up to 12 muffin halves in only 90 seconds, making it easy to keep up with the growing demands of the breakfast daypart.

The MT-12 toasts up to 12 halves (six complete English muffins) at one time. A temperature sensing control measures internal temperatures in the toasting chamber and adjusts the time accordingly. This produces perfectly toasted English muffins with the consistency you need to satisfy customers.

This unit also features an energy conservation mode that reduces power when the toasting chamber is empty. A partial load switch also allows operations to easily toast less than a full batch of English muffins during non-peak hours without wasting energy.

FEATURES

- Toasts 324 English muffins per hour; up to six English muffins (12 halves) at one time.
- Temperature sensing control measures internal temperature of the toasting chamber and adjusts time accordingly to produce perfectly toasted English muffins.
- Partial load switch for toasting three or less muffins.
- Energy conservation mode automatically reduces power consumption by 75% when toasting chamber is empty.
- Stainless steel and aluminum construction.
- Toaster alerts operator with an audible signal and a ready light when muffins are done.
- Removable crumb tray for easy cleaning.

Muffin Toaster | MT

Dimensions

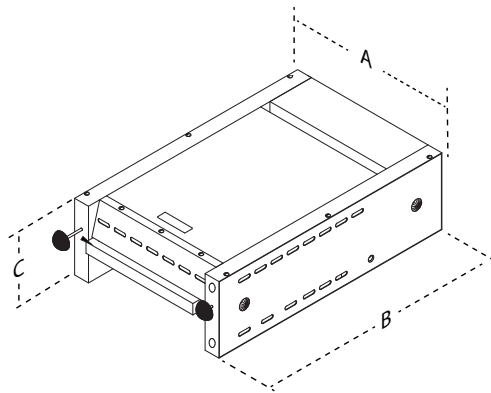

Model No.	Width (A)	Depth (B)	Height (C)
-----------	-----------	-----------	------------

MT-12	15 5/8" (397 mm)	26 5/8" (676 mm)	8 1/8" (207 mm)
-------	---------------------	---------------------	--------------------

Shipping Dimensions

Model No.	Height	Width	Depth	Weight
-----------	--------	-------	-------	--------

MT-12	13" (330 mm)	30" (762 mm)	20" (508 mm)	57 lbs. (26 kg)
-------	-----------------	-----------------	-----------------	--------------------

Electrical Ratings and Plug Configuration

Model & Mfg. No.	Volts	Watts	Amps	Hertz	Plug Description
MT-12 9200139 (Australia)	230	3400	14.8	50/60	AS3112 Australian Plug 20 Amp., 250 Volt
MT-12 9200146 (U.S. & Canada)	208	3400	16.4	50/60	NEMA L6-20P 20 Amp., 250 Volt Straight Twist Lock
MT-12 9200148 (Europe)	230	3400	14.8	50/60	IEC-309 16 Amp., 230 Volt Pin & Sleeve

Electrical Specifications

Timers:	Solid state
Time Range:	Temperature compensated
Temp. Control:	Solid state
Power Cord:	Six foot (1.83 m) three wire power cord supplied
Construction:	Stainless steel and aluminum
Crumb Tray:	Removable for cleaning

P/N 1020278 01/17