

TECHNICAL SHEET

PLANETARY MIXER ECOLINE

Bench spiral mixers with electronic speed variator



Models:

- ECO 10
- ECO 20
- ECO 20H
- ECO 30
- ECO 40
- ECO 60

General technical characteristics:

- Electronic variator (inverter SCHNEIDER);
- Three-phase motor with single-phase input;
- Stainless steel feet in floor standing planetary mixers;
- Manual operation;
- Standard equipment: spiral, blade and whisk;
- Removable stainless steel grid for cleaning.

Optional accessories:

- Special tension;
- Scraper;
- Trolley for bowl (for EC 30-40-60)
- Smaller bowls and tools available.

Warranty:

- One year, ⊗

⊗ warranty conditions

CP Bakery Equipment machines are covered by warranty against material or manufacturing defects for 12 months since the invoice date and subject to the conditions here under mentioned:

The warranty consists only in the ex works replacement of the faulty parts, except the electrical parts and motors. The purchaser will be reimbursed neither for the damage coming from the production stop nor for the labor coming from the installation of the new parts. Warranty is not valid in the following cases: the purchaser does not respect the payment terms; the damages are caused by overcharge, unskilfulness, abnormal use, poor maintenance, not authorized modifications, when irregular or lack of electric majeure. Manufacturing defects should be communicated to CP Bakery Equipment company to the e-mail address as soon as they appear.

Dimensions

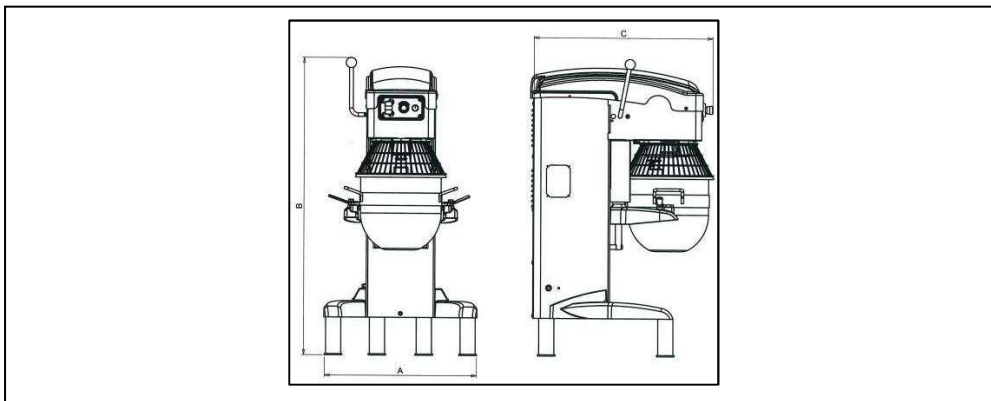

MODEL	A	B	C	Power [kW]	Bowl [liter]	Ø Bowl x H [mm]
ECO 10	600 (23")	775 (30")	560 (22")	0.5	10	Ø250x230 (Ø10"x9")
ECO 20	725 (28")	840 (33")	605 (24")	0.75	20	Ø315x290 (Ø12"x11")
ECO 20H	725 (28")	1180 (46")	605 (24")	0.75	20	Ø315x290 (Ø12"x11")
ECO 30	735 (29")	1180 (46")	605 (24")	1.1	30	Ø350x365 (Ø14"x15")
ECO 40	910 (36")	1355 (53")	700 (27")	1.5	40	Ø400x370 (Ø16"x14")
ECO 60	985 (38")	1490 (58")	730 (29")	2.2	60	Ø450x430 (Ø18"x17")

Voltage: 400V/3/50Hz
(*Optional:* special voltages 400V/3/60Hz)

Transmission belts.

Protections: emergency button and safety grid.

Control panel: you press the START button to start the machine, and STOP to stop it. The change of speed is via the potentiometer on the front panel.

Speeds: Planetary rpm 35-150; Spiral; Tool rpm ratio i=2,7.

Shipping information

Model	Net weight	Gross weight	
		Pallet	Cage
ECO 10	55kg (121lb)	65kg (143lb)	105kg (231lb)
ECO 20	108kg (238lb)	118kg (260lb)	158kg (348lb)
ECO 20H	128kg (282lb)	138kg (304lb)	178kg (392lb)
ECO 30	130kg (286lb)	140kg (308lb)	180kg (396lb)
ECO 40	205kg (451lb)	215kg (473lb)	255kg (562lb)
ECO 60	240kg (529lb)	250kg (551lb)	290kg (639lb)

Information on the packaging

MODEL	Box on pallet		Cage/Crate	
	Dimensions [mm]	Volume [m ³]	Dimensions [mm]	Volume [m ³]
ECO 10	750x700x1100 (29"x27"x43")	0.58 (20.5ft ³)	980x830x1160 (38"x32"x46")	0.94 (33.2ft ³)
ECO 20	750x700x1100 (29"x27"x43")	0.58 (20.5ft ³)	980x830x1160 (38"x32"x46")	0.94 (33.2ft ³)
ECO 20H	750x700x1500 (29"x27"x59")	0.79 (27.9ft ³)	980x830x1500 (38"x32"x59")	0.95 (33.5ft ³)
ECO 30	750x700x1500 (29"x27"x59")	0.79 (27.9ft ³)	980x830x1500 (38"x32"x59")	0.95 (33.5ft ³)
ECO 40	940x650x1600 (37"x25"x63")	0.98 (34.6ft ³)	1060x900x1550 (42"x35"x61")	1.48 (52.26ft ³)
ECO 60	1110x870x1770 (43"x34"x69")	1.69 (59.68ft ³)	1150x980x1830 (44"x38"x72")	2.02 (71.34ft ³)