

PRODUCT:

QUANTITY:

ITEM #:

Bid Specification

Unit construction offers stainless steel top, sides, and door liner with an aluminized steel oven liner and stainless steel door liner. The unit is insulated on all sides. Oven compartments has two ceramic phosphate decks 16 ½" x 16 ½" which are removable to allow for easy cleaning. Decks are 3-1/2" apart. Oven's thermostat range is 300F– 500F and includes a 15 minute timer. Thermostat controls three sheath-type electric elements. The locations of the three elements are: one under each deck and one at the inside top of the oven

**Countertop Deck Oven**

Standard Feature

- Enclosed electric cooking oven with 15 minute timer
- Two ceramic phosphates (asbestos free). Deck both removable for easy cleaning. Decks are 16 ½" x 16 ½"
- Decks are 3-1/2" (89mm) apart
- Each deck had stainless steel edging
- Thermostat range 300F– 500F with off position
- Three prong 6ft power cord supplied
- Stainless steel stop, four sides and all fasteners
- Insulated on all sides
- Balanced door, stay down in the open position
- Spring hinges allow door to remain closed
- Bakes pizza up to 16" diameter, cookies, casseroles, pretzels, hot sandwiches, and pies

Reliability backed by APW Wyott's Warranty

- APW Wyott Counter Deck Oven is backed by a 1 year part's & labor warranty
- Certified by the following agencies:



See reverse side for product specifications.

PRODUCT:

QUANTITY:

ITEM #:

Counter Deck Oven

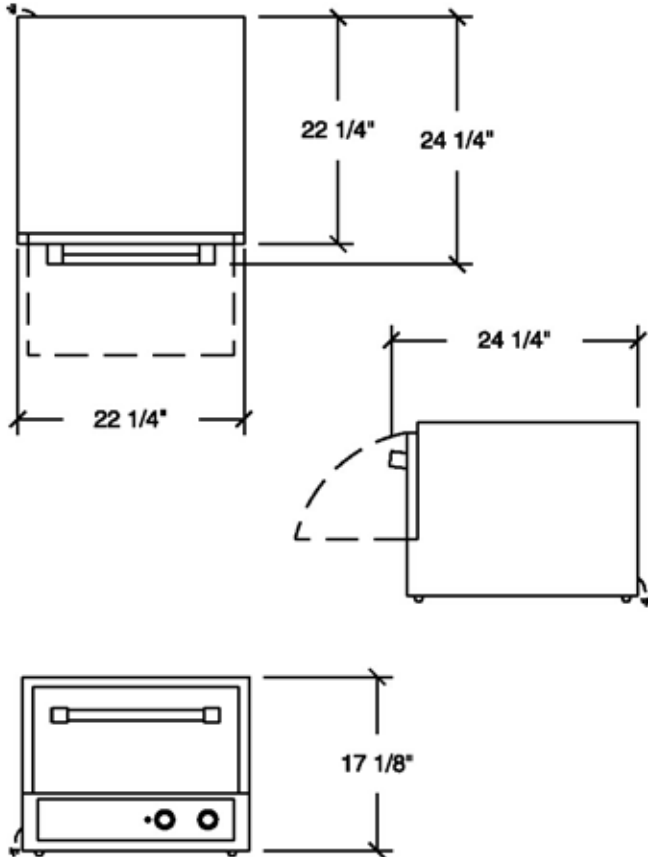

PRODUCT SPECIFICATIONS

Construction:

Stainless steel exterior with a welded aluminized steel interior. Insulated with a spring-loaded door to keep the door closed in the upright position
 Exterior- stainless steel outer panels and door
 Interior- aluminized inner liner with two easily removable ceramic phosphate shelves
 Legs- 1/2" rubber feet to prevent the unit from sliding on the counter top

Electrical Specifications:

120V, 1500W, 15 Amps
 208/240V, 1600/2140WW, 7.7/9 Amps
 220V 1830W, 8.3AmpsAmps

Overall Dimensions:

Exterior 17 1/8" H x 22 1/4" W x 24 1/4"D

Inside 2 shelves 16 1/2" x 16 1/2" with 3" of clearance

Shipping Information:

Weight 120lbs.

F.O.B. Cheyenne, Wyoming

*APW Wyott reserves the right to modify specifications or discontinue models without incurring obligation.