

Glasswasher

G404-12B

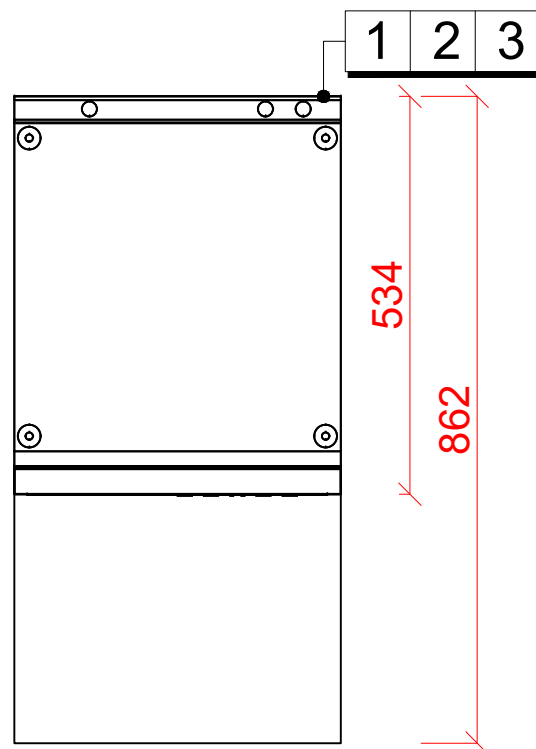
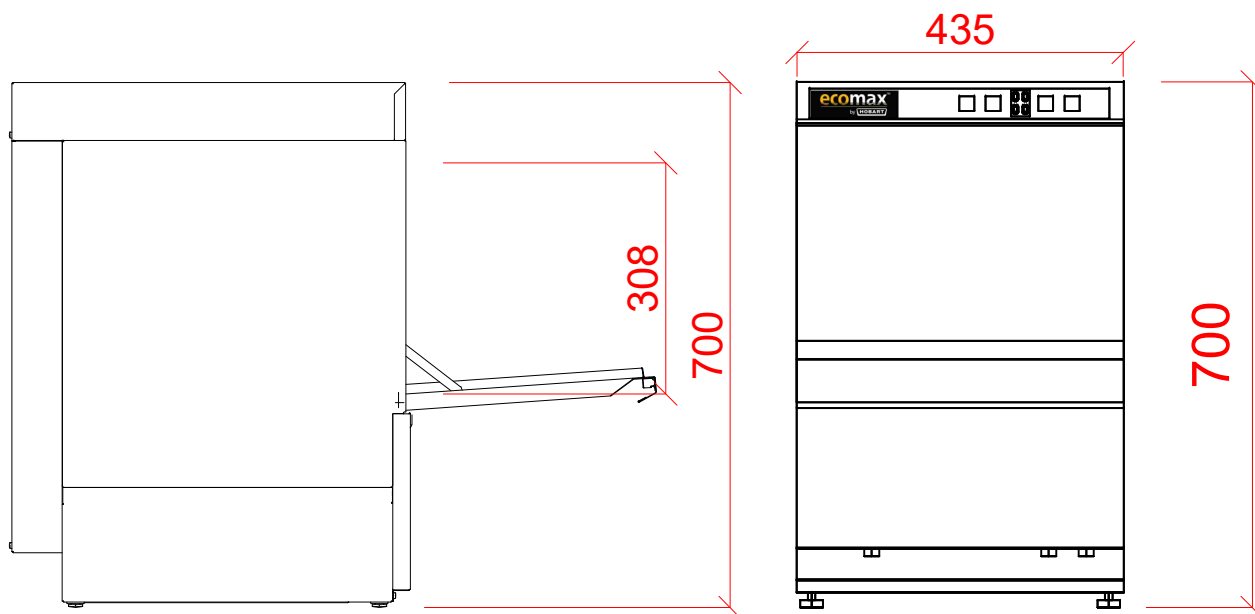

**1** Water

22mm CONNECTION VIA 2 METRE FLEXIBLE HOSE, FEMALE TERMINATION.

WATER SUPPLY 15°C TO 60°C (2° TO 8° CLARK MAX)@ 2.0 TO 6.0 BAR MAX. INITIAL TANK FILL 10 LITRES. RINSE WATER USAGE 2.0 LITRES PER CYCLE. MAX USAGE 120 LITRES PER HOUR.

**2** Drain

DRAIN: 2.0 METRE FLEXIBLE HOSE TO A 40mm TRAPPED STANDPIPE 650mm MAX A.F.F.L.

FLOW RATE 30 LITRES PER MINUTE.

**Other Services**

RINSE AGENT HOSE - 2.5 METRE FLEXIBLE.  
DETERGENT HOSE - 2.5 METRE FLEXIBLE.

**3** Electric

2.1kW 230/50/1 FUSED AT: 1 x 13amps  
CONFIGURABLE TO:  
5.8kW 400/50/3 FUSED AT: 3 x 16amps  
3.9kW 230/50/1 FUSED AT: 1 x 25amps

MACHINE SUPPLIED WITH 2.0 METRES OF CABLE

**Notes**

+40mm ADJUSTMENT FOR FEET.  
FOR RACK SIZE:  
385mm x 385mm to 396mm x 396mm